



**IMAGINE ,
INNOVATE,
INSPIRE**



API Compliant Steam Turbines



Triveni Turbine Limited

Over the last 50 years, Triveni Turbines has been offering robust, reliable and efficient steam turbine solutions globally. We are one of the world's largest manufacturers of industrial steam turbines ranging up to 100 MWe, addressing the specific needs of a customer and can work across a wide range of pressure and flow applications.

With more than 1 billion operating hours of turbine fleet, we have installed more than 6,000 steam turbines, by generating more than 16 GW power generation capacities in 20 plus industries worldwide.

Triveni Turbines is present in over 80 countries around the world, and the steam turbines are manufactured at our world-class facilities located in Bengaluru, India. Our products are installed in diverse industries for Power Generation, Heating and drive applications namely Petroleum Refineries, Chemicals, Petrochemicals, Fertilizers, Sugar, Distillery, Cement, Steel, Pulp & Paper, Textiles, Palm Oil, Food Processing, to Biomass and Waste to Energy, among others.

Triveni Turbines with its global expertise and local manufacturing excellence has helped its customer by understanding their requirements in detail and offer its API 611 and API 612 compliant steam turbines, globally. Triveni's API compliant steam turbines are also prequalified with globally reputed National Oil Companies, Original Equipment vendors and EPC/PMC companies.

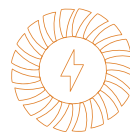

16 GW+
OF INSTALLED
CAPACITY



80+
COUNTRIES OF
PRESENCE



20+
INDUSTRIES
SERVED

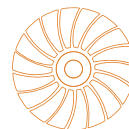

6000+
STEAM TURBINES
INSTALLED



350+
ANNUAL TURBINE
MANUFACTURING
CAPACITY



**API STEAM
TURBINES
TO OIL & GAS
INDUSTRIES**

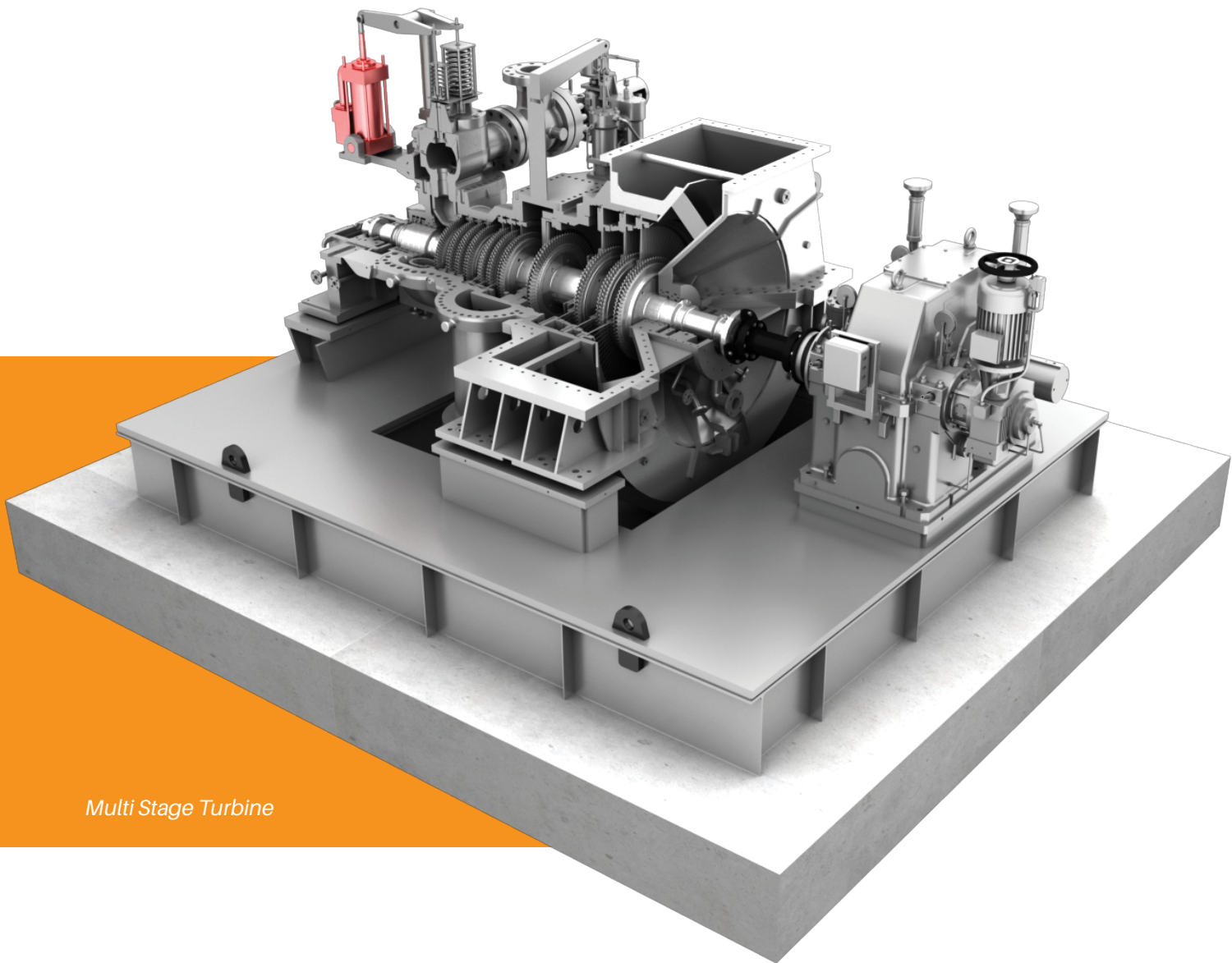

Multi Stage Turbine

API Product **Portfolio**

Triveni Turbines offers a wide range of API compliant steam turbines from 5kW upto 100MW range in back pressure and condensing modes suitable for applications in Petroleum Refineries, Chemicals, Petrochemicals and Fertilizers.

Triveni Turbines' API compliant steam turbines are designed for installation in harsh weather conditions (desert, coastal, tropical, frigid). Triveni customizes its products for both Safe and Hazardous area installations.

Our products are suitable for continuous essential and non-essential applications. Modular concept of construction allows highest degrees of customization to match the most stringent project specifications.

Global Presence

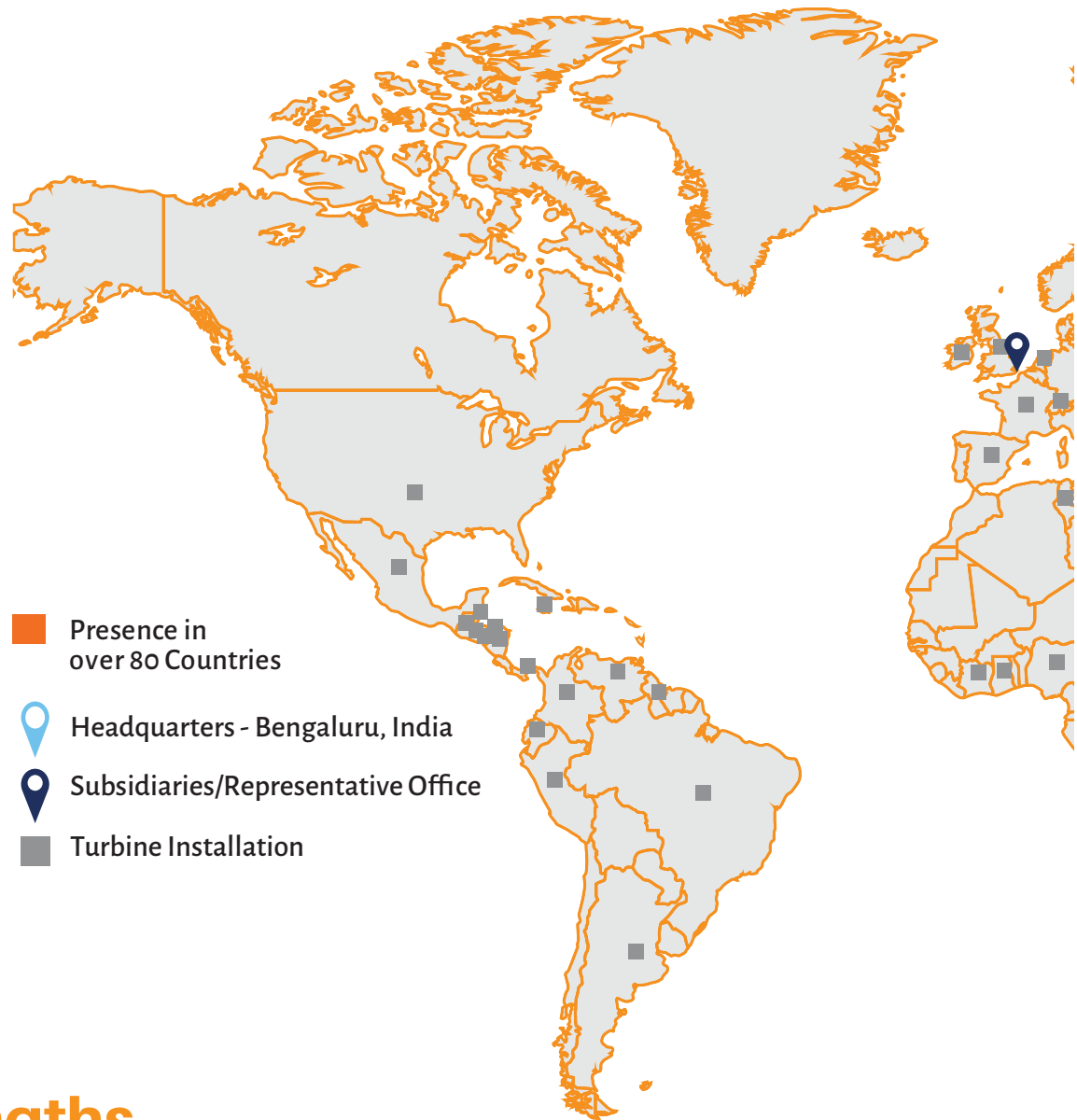

Our Strengths

Proven track record of manufacturing steam turbines compliant to highly stringent Shell Design Engineering Practices (DEP) over and above API standards.

Wide range of API 611 & 612 compliant steam turbines from 5 kW to 100 MW.

API 677 & 613 and Shell DEP compliant general & special purpose high efficiency gear units.

Complete Turnkey Solutions. (Erection & Commissioning, Annual Maintenance Contracts, Lifetime Spares Support).

Engineering and supply of complete Steam Turbine package including accessories (Panels, Power evacuation systems, control & monitoring (MCMS, DCS / PLC) solutions.

System Engineering of complex Control & Instrumentation suitable for hazard area installation with IEC Ex, ATEX and other statutory compliances.

Turbines, gear units and Lube Oil consoles suitable for outdoor installation in desert / marine / frigid environments with careful selection of materials as per International standards (ASTM / DIN / IS / BS etc).

Exhaustive product line from proven modular building blocks.



Engaging with Global Clientele.

Heightened Engagement with reputed International EPCs, Licensors, PMCs such as

- ★ Fluor
- ★ L & T Hydrocarbons
- ★ NIOEC
- ★ Engineers India Limited
- ★ Projects & Development India Limited
- ★ Haldor Topsoe
- ★ Chemicals & Allied Industries (Oman)
- ★ Abu Dhabi National Oil Company
- ★ Indian Oil Corp.
- ★ Technip FMC
- ★ Maire Tecnimont
- ★ Linde Engineering
- ★ Qatar Petroleum
- ★ Petrojet
- ★ Saudi Arabian Basic Industries Corporation (SABIC)
- ★ Egypt General Petroleum Co (EGPC)
- ★ Qatar Fertilizers
- ★ AMEC Foster Wheeler (Wood PLC)
- ★ Worley
- ★ Tata Consulting Engineers (TCE)
- ★ Toyo Engineering
- ★ Mc Dermott International
- ★ Bechtel Corporation

Engagement with reputed OEM's

- ★ Mitsubishi Heavy Industries
- ★ Toshiba
- ★ Atlas Copco
- ★ Flowserve Corporation
- ★ Sulzer Ltd
- ★ Boldrocchi Group
- ★ ITT Corporation
- ★ KSB Pumps

API Single Stage Turbines

API 611 compliant Single Stage turbines offer low footprint, wide speed range, wide range of steam conditions, multiple options to cater to the user's operational needs.

Triveni Turbines' robust single stage turbines are suitable for driving

- ★ Boiler Feed Water Pumps
- ★ Cooling Water Pumps
- ★ Process Fluid transfer Pumps
- ★ Compressors
- ★ ID & FD Fans
- ★ AC Generators

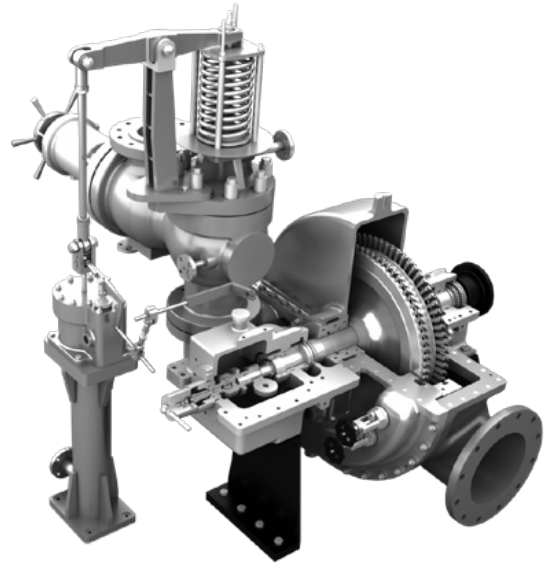

Features

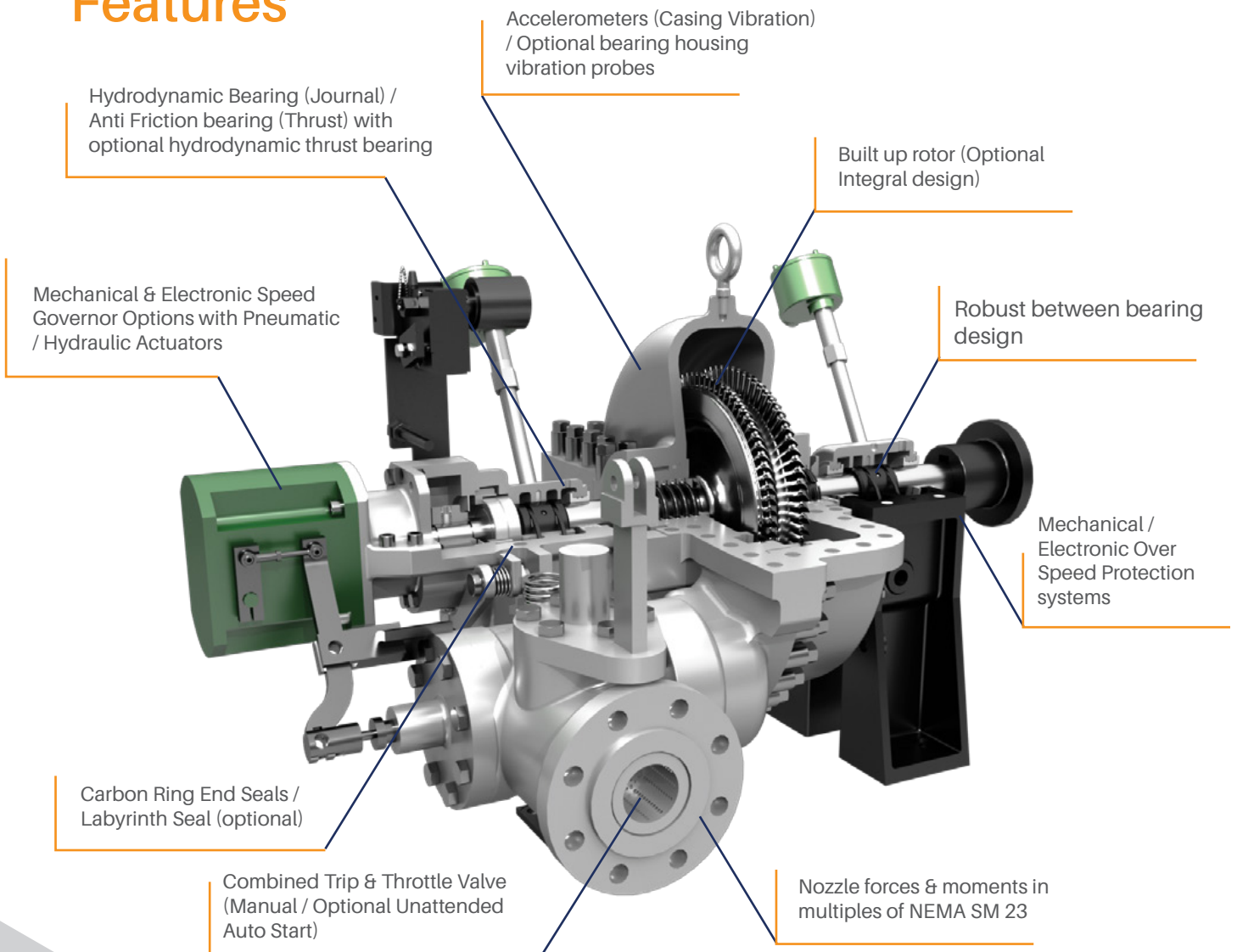

API Multi Stage Turbines

Engineered Multi Stage Turbines compliant to API 611 and API 612. Modular building blocks provide great flexibility to our customers while selecting the turbines for a wide range of steam operating conditions, driven equipment and processes.

Triveni Turbines' highly reliable & durable multi stage turbines are suitable for driving

- ★ Boiler Feed Water Pumps
- ★ Cooling Water Pumps
- ★ Compressors
- ★ ID & FD Fans
- ★ LT & HT AC Generators

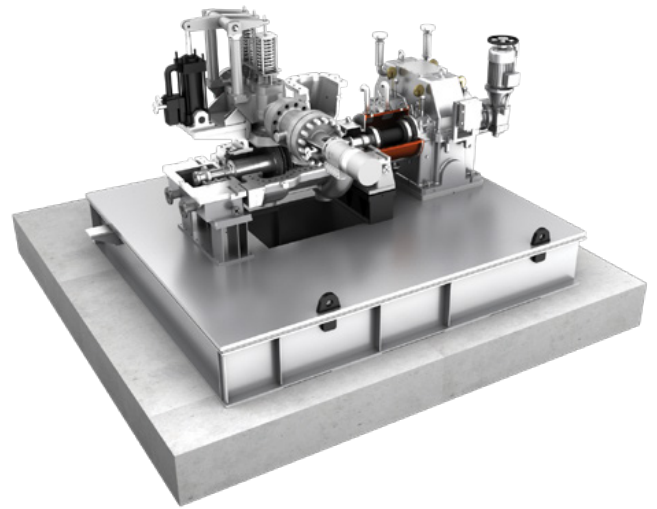

Features

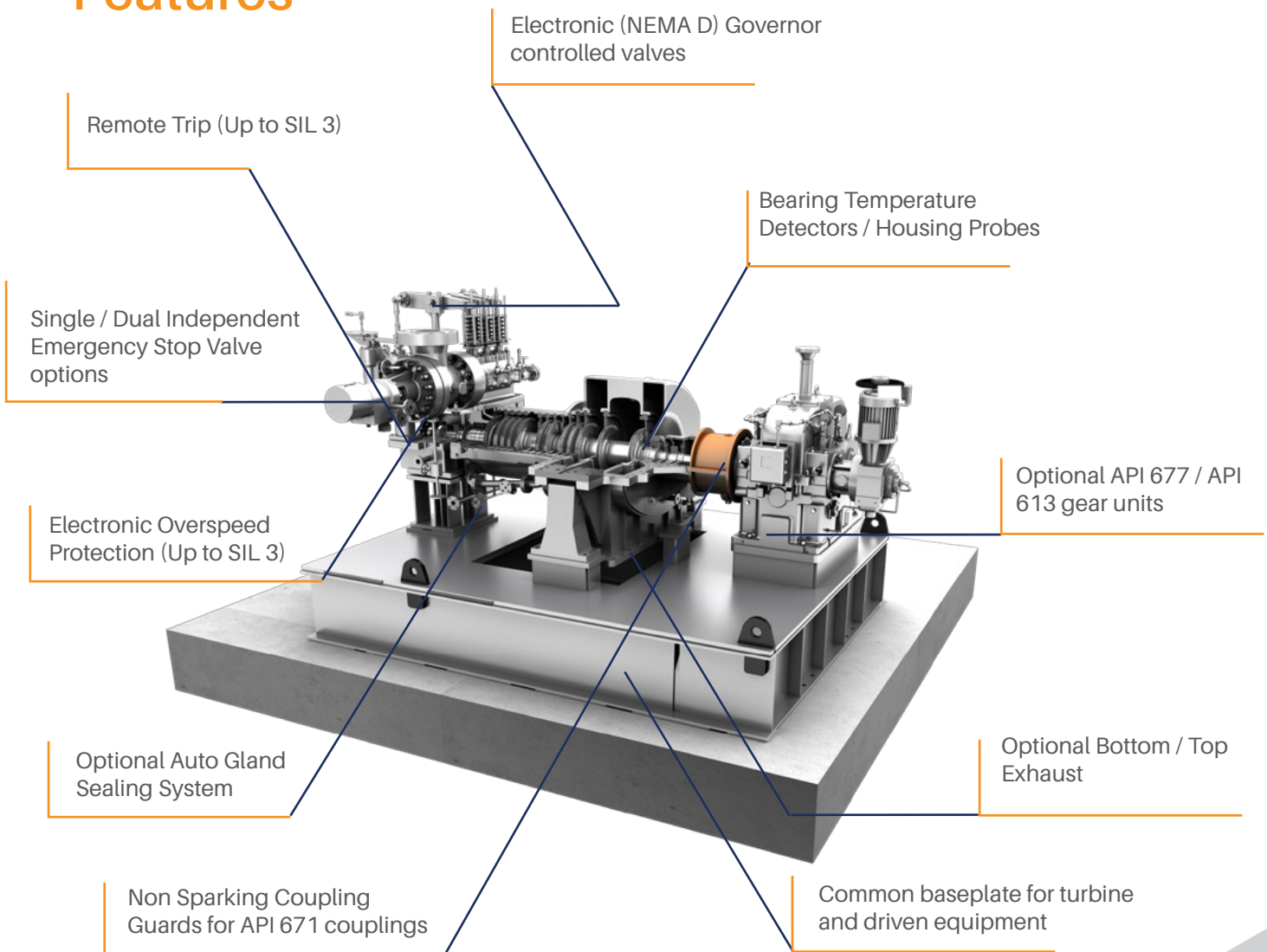

API 611 **General Purpose** Steam Turbines

API 611 compliant single and multi stage steam turbines are available in the range 30 kW to 15 MW for various drive applications and power generation.

- ★ Boiler Feed Water Pumps
- ★ Cooling Water Pumps
- ★ Process Fluid transfer Pumps
- ★ Compressors
- ★ ID & FD Fans
- ★ LT AC Generators

SLN	1	2	3	4	5	6	7	8	9	10	11	12
Model	TST 1003 Series	TST 1008 Series	TST 1015 Series	TST 1018 Series	TST 1025 Series	TST 1030 Series	TST 1060	TST 1120	TST 2025	TST 2030 Series	TST 2010 Z Series	TST 2150 Z Series
Turbine Type	BP	BP (Horizontal/Vertical)	BP	BP	BP	BP	BP	BP	Condensing	Condensing	BP & Condensing	BP & Condensing
Max Inlet Pr in kg/cm ² g / psi g	64	64	64	64	64	72	85	110	72	72	85	85
Max Inlet temp °C / °F	485	485	485	485	485	510	530	550	510	530	485	530
Max Exhaust Pr in kg/cm ² g / psi g	9	24	9	18	18	18	32	45	-0.533	-0.533	-0.533 till 45	-0.533 till 45
Max Speed in RPM	7000	7500	6000	7500	7500	7500	7500	6900	7500	7500	7500	6900
Max Rating in kW	600	3000	3000	4000	3000	5000	8000	15000	2500	5000	1500	15000

TST 1003 SERIES

Back Pressure Steam Turbines Upto 600 kW
Single Stage Turbine

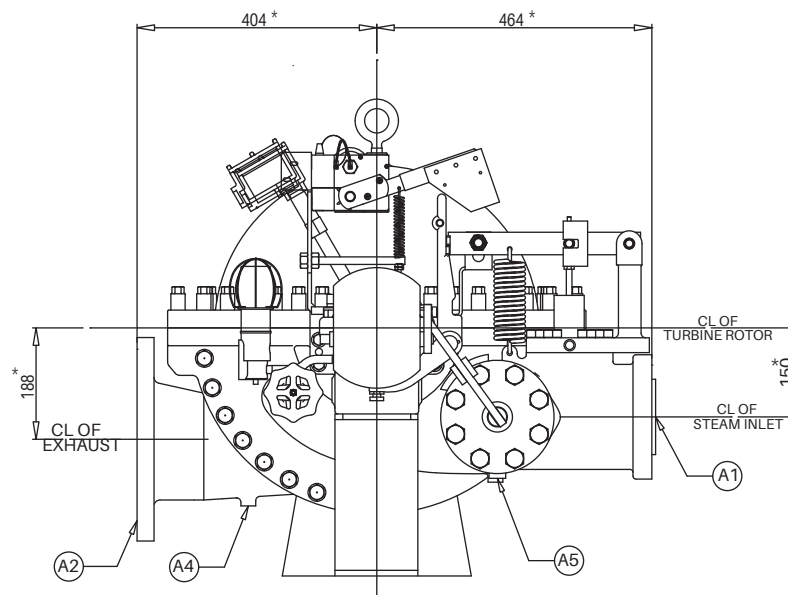

Inlet Steam Temp	Power	Exhaust Pressure	Speed in RPM	Inlet Diameter	Exhaust Diameter
485°C	600 kW	9 kg/cm ²	Up to 7000	3" / 76.4 mm	8" / 203.2 mm

TST 1008 SERIES

Back Pressure
Steam Turbines Up
to 3000 kW Single
Stage Turbine

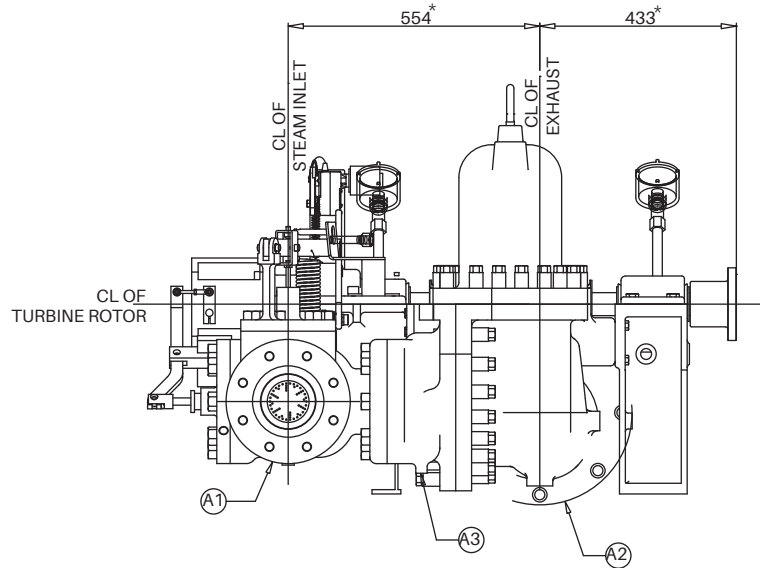

Inlet Steam Temp	Power	Exhaust Pressure	Speed in RPM	Inlet Diameter	Exhaust Diameter
485°C	3000 kW	24 kg/cm ²	Up to 7500	4" / 101.6 mm 6" / 152.4 mm	8" / 203.2 mm 12" / 304.8 mm

TST 1018 SERIES

Back Pressure
Steam Turbines
Up to 4000 kW
Single Stage
Turbine

Inlet Steam Temp	Power	Exhaust Pressure	Speed in RPM	Inlet Diameter	Exhaust Diameter
485°C	4000 kW	24 kg/cm ²	Up to 7500	6" / 152.4 mm	12" / 304.8 mm

Features of Triveni API 611 Compliant Single Stage Steam Turbines

Base Features

- ★ API 611 compliant steam turbines
- ★ Manually operated Stop Valve
- ★ Oil Relay (NEMA A) Governor
- ★ Mechanical Over speed Trip mechanism
- ★ Carbon ring end seals
- ★ Hydrodynamic (Sleeve) Journal and Anti Friction (Ball) Thrust bearings
- ★ Built Up Rotor, Between bearings design
- ★ Direct / Gear drive options
- ★ Suitable for Outdoor / indoor installation

Optional Features

- ★ NEMA D Electronic Governor
- ★ Unattended Auto Start
- ★ Pneumatic Actuator
- ★ Hydrodynamic Journal and Thrust bearings
- ★ Integral rotor (Forged shaft and discs)
- ★ Electronic Over Speed Protection System (Up to SIL 3)
- ★ Up to SIL 3 rated Solenoid Valves for remote tripping and Partial Stroke test
- ★ High Back Pressure (exhaust) with Labyrinth Seal arrangement

API 612 Special Purpose Turbines

API 612 compliant steam turbines are available in the range 1.5MW to 30MW for various drive applications and power generation.

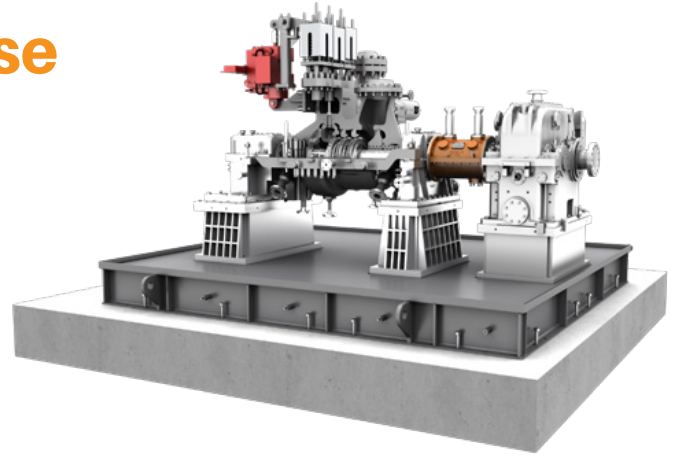

TST 1025 & 1060 SBH Series

- ★ Variable Speed High Back Pressure Multi-Purpose Steam Turbines
- ★ Designed as per API 612 + Shell DEP with further customization capabilities. Can be offered as API 611 variants as well.
- ★ Very High Back pressure capability (up to 45 barg / 652 psig)
- ★ Common baseframe for turbine and API (677 / 613) gear unit designed as per API RP 686
- ★ Suitable for installation in harsh outdoor environment with extremely low MDMT (-30°C) and high ambient temperature of up to 50°C
- ★ Instrumentation Suitable for both safe and hazardous area installation
- ★ Ex 'd' Electro Hydraulic Actuator
- ★ Ex 'd' SIL 3 rated Solenoid Valve
- ★ SIL 3 rated Emergency Stop Valve
- ★ Ex 'ia' instrumentation and Local Control Station
- ★ Skid Mounted Ex 'ia', Ex 'd', Ex e and Foundation Field Bus Instrumentation (IEC Ex / ATEX Certification)
- ★ Active type speed probes for long distance connectivity
- ★ Valves and piping designed as per Shell MESC (Material and Equipment Standards and Codes)
- ★ Prime mover in dual drive arrangement
- ★ Designed and built for service life of 30+ years
- ★ Designed and built for highly extended uninterrupted operation periods.
- ★ Removable cover thermal insulation.
- ★ Complete Turbine designed with full compliance to Human Factor Engineering.
- ★ Top / Bottom Steam entry and exit options

Maximum Operating Capabilities

SLN	1	2	3	4	5	6	7	8	9	10	11	12
Model	TST 1018 Series	TST 1025 Series	TST 1060 Series	TST 2030 Series	TST 2080 Series	TST 2180 Z Series	TST 2230 Z Series	TST 2300 Z Series	TST 4H Z	TST 6H Z	TST 8H Z	TST 10H Z
Turbine Type	BP	BP	BP	Condensing	Condensing	BP & Condensing	BP & Condensing	BP & Condensing	BP & Condensing	BP & Condensing	BP & Condensing	BP & Condensing
Max Inlet Pr in kg/cm ² g	64	64	85	72	72	87	140	140	145	145	1145	145
Max Inlet temp °C	485	485	530	530	530	515	545	545	565	565	565	565
Max Exhaust Pr in kg/cm ² g	24	18	32	-0.533	-0.533	-0.533/ till 45	-0.533/ till 45	-0.533/ till 45	-0.533/ till 45	-0.533/ till 45	-0.533/ till 45	-0.533/ till 45
Max Speed in RPM	7500	7500	7500	9000	9000	9000	9000	9000	6900	5000	3600	3600
Max Rating In kW	4000	3000	8000	5000	8000	18000	23000	30000	50000	65000	80000	100000

*For other sizes kindly contact the sales and marketing

Delivering **Highly Engineered & Robust API Compliant** Steam Turbines

High Pressure Casing:

- Horizontal Flange (no Vertical Joints)
- Studs with Cap-nuts
- Flange design as per 3 x NEMA SM 23
- Bleed / drain - weld connection

High Alloy Material:

- HP Casing
- Rotor
- Blades / Nozzles
- SEV & TV body and internals
- MDMT suitable for sub zero ambience

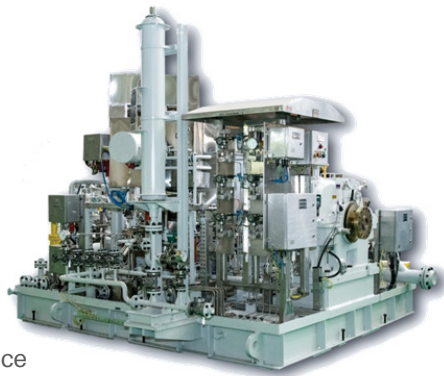

Bearing Pedestal:

- Tilting / Sliding type
- Tilting Pad - Journal Bearing & Thrust Bearing
- Multiple RTD provision
- Multiple Vibration probes

Skid mounted Gauge Board with

- IP 65, ATEX / IEC Ex Certified Instrumentation
- Intrinsically Safe / Explosion Proof Instrumentation
- HART / Foundation Field bus Instrumentation

ESV and TV:

- Electro - Hydraulic actuator
- Quick response (SIL-III)
- Complete Auto and Electronic

Compact System:

- Single skid
- Dynamically Integrated train
- Compliant to Human Factor Engineering requirements

Delivering **Highly Engineered & Robust API Compliant** Steam Turbines **accessories**



- ★ Shell MESC (Material Equipment Standards and Codes) compliant Valves
- ★ Walkways, Platforms and Ladders from Health and Safety compliance
- ★ Compact System:
 - Single skid
 - Compliant to Human Factor Engineering requirements
- ★ TEMA R Shell & Tube Heat Exchangers with ASME Code Stamp
- ★ Winterization / Tropicalization as per project requirements

Best in Class **Steam Path Design**

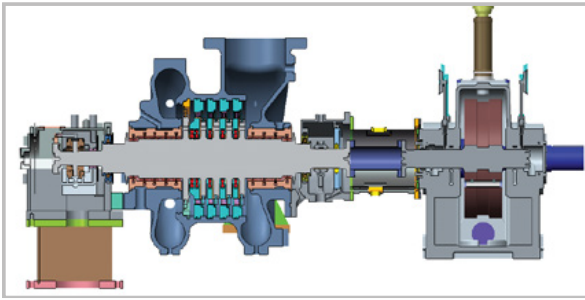

Thrust Bearing:

- Tilting Pad type
- Designed for variable load
- Equipped with multiple RTD

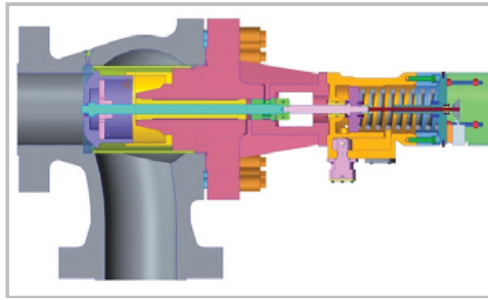

Emergency Stop Valve:

- Online check
- Wear resistant Valve seat
- High pressure Hydraulic actuator

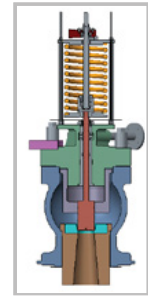

Throttle Valve:

- Zero gland system
- Wear resistant Valve seat

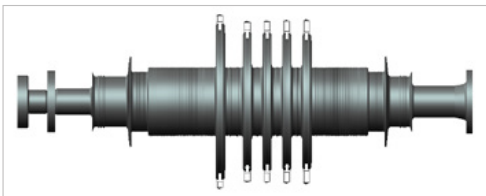

Rotor and Blade:

- Design for Overspeed
- Provision for multi plane balancing
- Verified for LCF and HCF life
- Rotordynamics (Lateral and Torsional) - satisfy the API requirements
- Integral flange

Blade Path:

- Optimised end and internal Gland system
- Optimised axial and radial clearances considering transient effects (start-up / shut-down)

High-End Engineering for Optimum Turbine Design

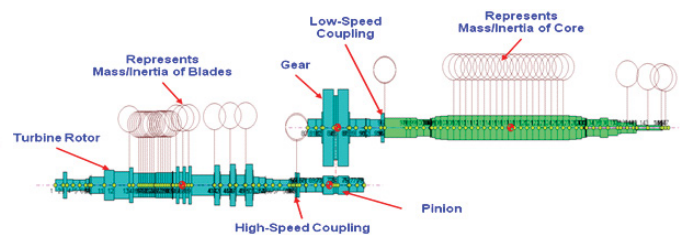
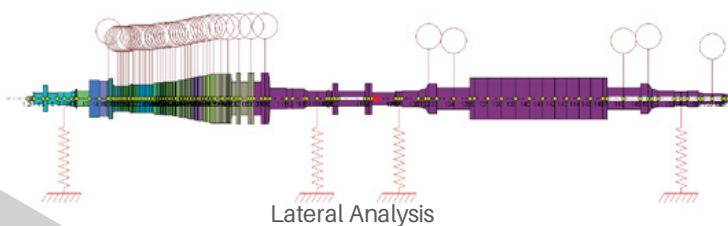
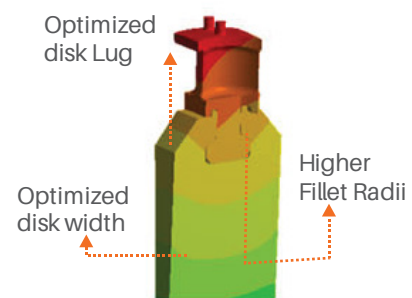
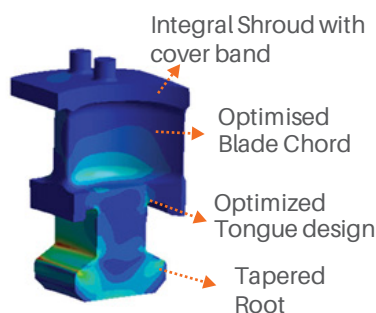
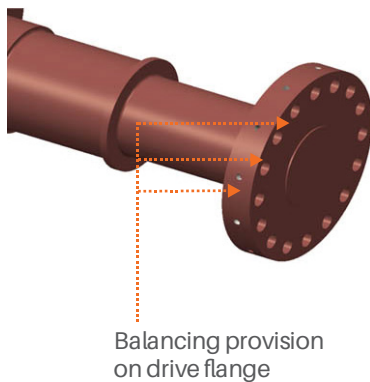

Over speed calculation based on entrapped steam and SEV closure time

Manufacturing Excellence

Our state-of-the-art facility, with an installed capacity to manufacture over 350 turbines annually, is equipped to provide complete manufacturing, assembly, testing and refurbishing services. The facility is equipped with precision equipments and the latest softwares for seamless manufacturing of all critical components. Our in-house manufacturing for all critical components along with a strong network of global suppliers enables faster delivery of products to our customers.



General & Special Purpose Steam Turbines

- ★ No Load Mechanical Run Test (NLMRT) Inspections (Optional Witness by Customer / Customer nominated Third party inspection agency)
- ★ As per API 611 (4th / 5th edition) for General Purpose Steam Turbines
- ★ As per API 612 (6th / 7th edition) for Special Purpose Steam Turbines - Unbalance response test and lateral speed verification carried out in High Speed balancing vacuum tunnel (in lieu of during NLMRT)
- ★ Triveni Turbine Limited - Manufacturing of Turbines up to 20 MW with Live superheated steam at 14 kg/cm²g and 200°C and from 20 MW to 100 MW with live superheated steam at 40 kg/cm²g and 400°C)



Manufacturing – IT Enabled Operations

Business Software

- SAP - HANA
- Salesforce.com
- Primavera
- IOT - Fleet RMD
- IOT- CNC shop
- ITO- Cost tools
- OTR- Primavera

Technical software

- CFX
- ANSYS
- Concepts Aero Suite
- Dyrobes, ARMD
- PLM-Teamcentre
- Pro-E, Unigraphics
- Ax-turbo
- MISES
- ThermoFlow, Gatecycle
- Matlab



Comprehensive **Service Solutions**

We offer a unique combination of the latest equipment, a highly skilled team and OEM expertise to provide a comprehensive range of customised service solutions for industrial steam turbines. Our aim is to deliver total customer satisfaction and this customer centric approach has enabled us to attain extremely high repeat customer orders. Our customers can visit the facility during the repair process and review the progress.

Service **Offerings**

Full speed **Schenck Rotec** vacuum balancing tunnel for balancing turbines, compressors/alternators.

Overhauling & troubleshooting.

Customisation & upgradation of old turbines for both industrial and utility segments.

Refurbishment solutions for higher MW turbines, upto 500MW for all makes.

- Efficiency restoration/improvement
- Health survey & condition assessment
- Relocations of turbine
- Upgradation
- Re-engineering
- Full speed balancing under vacuum
- Retrofitting turbovisory systems
- Modernisation of power plants
- Indigenisation
- Residual Life Assessment



Case Study 1

Oil Refinery in Middle East

Driven by: Triveni 4 Nos. 1.5 MW and 4 Nos. 2.7 MW Steam Turbines as per API 612 + Shell DEP + AMEC FW Project Variations



2.7 MW Steam Turbine



1.5 MW Steam Turbine

- Steam Turbines designed, manufactured & tested as per API 612 6th edition + Shell DEP + AMEC FW Project variations
- 4 x 1.5 MW and 4 x 2.7 MW Steam Turbines drive 4 nos. each Combustion Air Blower and Flue Gas Fans respectively for the world's largest reformer package (once commissioned)
- Project executed with approved deviations to complete project specifications
- Turbines Designed for outdoor installation with MDMT suitable for -3°C
- Electrical Hazard Area Zone 1, II C, T3

- Steam Turbines constructed in full compliance with Shell DEP / AMEC PV requirements for Human Factor Engineering
- Steam Turbines constructed for long service life of 30 years and uninterrupted operation of 6 years
- Steam Turbines, Gear Units, Lube Oil Units, Unit Control Panels, Gland Steam Condensers in Triveni Scope of supply

Case Study 2

Oil Refinery in India

Powered by: Triveni 5 Nos. 12 MWe Steam Turbine Generator Sets as per API 612



12 MWe Steam Turbine Generator during installation

- Steam Turbines inlet steam 41.35 bara, 370° C as per API 612 commissioned during 2008-09, 2014
- Gear boxes as per API 613 | Lube oil system as per API 614
- Air Cooled Oil Cooler as per API 661
- PLC - Alan Bradley (Failsafe) with redundancy and SIL-3 rating
- Machine Monitoring System (MMS) Bentley Nevada model 3500 series with System 1 Analysis system
- 12 MW AC Generator, IP 54 enclosure, Class F Insulation, Air cooled CACA, 50° C Ambient

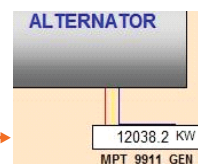
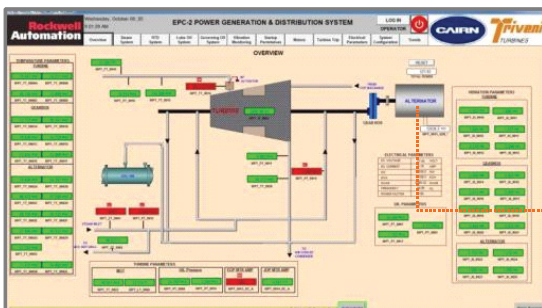

Case Study 3

Oil Refinery in Middle East



7 MWe Steam Turbine Generator during installation

Powered by: Triveni 4 Nos. 7 MWe Steam Turbine Generator Sets as per API 612

- Steam Turbines inlet steam 41 bara, 380 Deg C as per API 612 commissioned during 2012-13
- Lube oil system as per API 614
- Surface Condensers suitable for Sea Water Cooling (Cu-Ni Tubes)
- PLC - Siemens S7 400-FS (Failsafe) with redundancy and SIL-2 rating
- Machine Monitoring System (MMS) Shinkawa, Japan model VM-5 with RV-100 Analysis system
- 7 MW AC Generator, IP 54 enclosure, Class F Insulation with Sea water cooled Air cooler (Cu-Ni tubes)

Case Study 4

Chemical Plant in Saudi Arabia



Steam Turbine prepared for dispatch after completing FAT with live steam

Powered by: Triveni 710 kW Steam Turbine for driving Blower

- Existing Gardner Denver Blower at site driven by by competitor turbine manufacturer
- Replaced with Triveni turbine as customer is not satisfied with the performance and support from the existing turbine manufacturer.
- One-to-one footprint replacement. Turbine designed to suit the existing foundation
- Turbine compliant to API 611 and with variable speed operation

Case Study 5

Chemical Plant in India



8287 kW Steam Turbine Steam driving 60000 ACFM

Driven by: Triveni 1 No. 8.28 MW for world's largest Air Compressor (Volumetric flow wise)

- Steam Turbines inlet steam 105 bara, 535 Deg C and exhaust at 7.3 bara as per API 612 commissioned during 2018
- Lube oil system as per API 614
- Driving Ingersoll Rand make Centrifugal Air Compressors

Case Study 6

Leading Refinery in India

4 no.s Triveni Steam Turbines for Various pump units

- The steam turbines of following ratings were supplied to the end user.
 - 1 x 22 kW , 3000 Rpm
 - 1 x 55 kW , 3000 Rpm
 - 1 x 90 kW , 3000 Rpm
 - 1 x 255 kW , 3000 Rpm
- API 611 Steam turbine with Mechanical governor and pneumatic ON/OFF valve
- Steam Pressure - HP to MP (44kg/cm²g to 17 kg/cm²g)

Case Study 7

Leading Refinery in Mexico

12 no.s Triveni Steam Turbines for Various pump units

- The steam turbines of following ratings are executed for the refinery in Mexico.
- API 611 Steam turbine with Peak200 governor & Pneumatic actuator
- > 37 kw to 1500 kw various Direct drive and Gear Direct units

Case Study 8

Leading Refinery in India

1Nos 3.6 MWe , API612 Direct Drive

- Dual Drive of Motor Cum generator and Compressor
- Project delivered in record time in 9 months
- Low Pressure inlet

Triveni Turbines key takeaways

Reliability

- Triveni API Steam turbines are fully compliant to API code + Shell DEP with stringent specifications
- Combined experience from having successfully commissioned over 5000 turbines in more than 70 countries across industry segments

Environment, Health & Safety

- Eco friendly Steam turbines that are net power producers, make less noise and demand lesser consumables
- Assures health and safety of operating and maintenance staff with Human Factor Engineering

Availability

- Robust design, construction of turbines by skilled foremen with hundred of years of experience
- Our turbines across the globe have clocked tens of millions of uninterrupted operating hours.

Cost optimization through Value Chain

- Lower Production Cost owing to over 200 turbines manufactured per year (Economies of Scale)
- Benchmark manufacturing practices that ensure waste elimination reducing overheads
- High efficiency steam turbines that reduce operating cost (reduced fuel consumption)

Global Network

INDIA

SALES, SERVICE AND MANUFACTURING FACILITY

Triveni Turbine Limited

12-A, Peenya Industrial Area,
Bengaluru-560 058,
Karnataka, India.
Phone : +91 80 22164000
Fax : +91 80 22164100

www.triveniturbines.com

UAE

SALES AND SERVICE OFFICE

Triveni Turbines DMCC

Unit No: 4502-016,
Mazaya Business Avenue BB2,
Jumeirah Lakes Towers,
Dubai, United Arab Emirates.
Phone : +971-4567 0752

SALES, SERVICE AND MANUFACTURING FACILITY

Triveni Turbine Limited

Plot No.491, Sompura
2nd Stage, KIADB Sompura
Industrial Area
Nelamangala Taluk,
Bengaluru Rural - 562 123

SOUTH AFRICA

MARKETING AND SERVICE OFFICE

Triveni Turbines Africa Pty Limited TSE Engineering Pty Ltd

252, Vonkprop street, Samcor
Park, Pretoria, Gauteng 0184.
Phone : 0011 8420700
Mobile :- +27 84 973 3023

UNITED KINGDOM

REGISTERED OFFICE

Triveni Turbines Europe Private Limited

th Floor, 50 Broadway,
London, SW1H 0DB.
Phone : 020 3872 7345

www.triveniturbines.co.uk

THAILAND

MARKETING AND SERVICE OFFICE

Triveni Turbines DMCC

571 RSU Tower, Unit 903,
9th Floor, Sukhumvit
31 Road, Klong Ton Nua,
Wattana, Bangkok 10110,
Thailand
Phone : +66 2 117 9575,
Fax : +66 2 662 3416

Corporate
Video



Visit Website





© Copyright January 2024 Triveni Turbine Ltd.

All rights reserved. No part of this brochure may be reproduced, copied, translated, adapted and so on or stored in a retrieval system, tapes, discs, microfilms and so on or transmitted in any form or by any means of electronic, mechanical, photocopies, recording or otherwise, without the written permission of Triveni Turbine Limited

Visit our Website

